

GREAT MINCE 22

WMG-22



WATANABE SPECIAL BARREL KEEPS THE FRESHNESS OF MEATS AFTER GRINDED!!



SPECIAL BARREL

**THE FEEDSCREW AND BARREL ARE
CARTRIDGE TYPE**

QUIET CONSTRUCTION

BOX TYPE

COMPACT DESIGN

SAFETY DEVISE

KEEP FRESHNESS OF MEATS WELL!

The special barrel keeps the freshness of products.

WELL SANITARINESS

The barrel, feeding screw, locking ring, and meat tray are all stainless steel made.

SIMPLE AND COMPACT MACHINE

The new simple and compact design gives more space to operate.

SAFETY DEVISE

The top priority of this machine is a safety. The centre of the machine design is a protector.

EFFICIENT USE

The wider meat tray gives you more efficient operation.

EASY TO ATTACH/ DETACH THE BARREL AND FEEDING SCREW

Only one lever for attaching/detaching them. Easy to be cleaned up!

FOOT SWITCH (OPTIONAL)



■ SPECIFICATION

DIMENTION	W455×D640×H510mm
MOTOR	3P 200V 1.5 kW
PROCESS AMOUNT	450 kg / h (3.2mm plate)
MAX. PROCESS SIZE	○φ50 mm · □35 mm
TEMPERATURE	More than -4°C (DEPENDS ON MEAT, SHAPE and THICKNESS)
WEIGHT	60 kg

■ DRAWING Please refer to the drawing for further information .

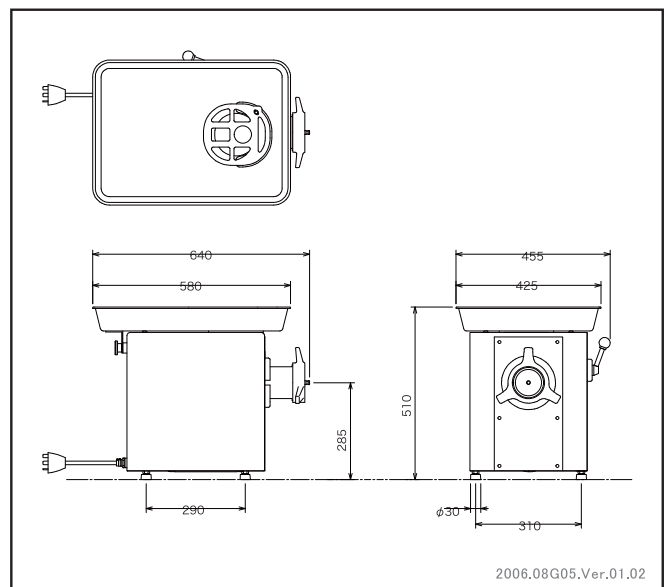

WATANABE
WATANABE FOODMACH CO.,LTD.

2-12-26 TSUYUHASHI NAKAGAWA-KU NAGOYA JAPAN
TEL052-361-8511 FAX052-361-8490
URL:<http://www.foodmach.co.jp/>

SALES AGENT